

High-accuracy Non-contact In-line Measuring System
Laser Scan Micrometer
LSM-02-A/30-A/CU-A



Solutions for high-accuracy measurements of outside diameters in the era of in-line inspection

Our advanced sensor technologies bring new value by helping create a connected smart factory.



Its thin profile makes it easy to mount on a DIN rail and suitable for installation in a distribution board

APPLICATION

Measurement of catheter and magnet wire



Measurement of roller bearing



Simultaneous measurement of roller outside diameter and deflection



Measurement of film sheet thickness



Note: The laser in the picture is for illustrative purposes only.

SYSTEM CONFIGURATION

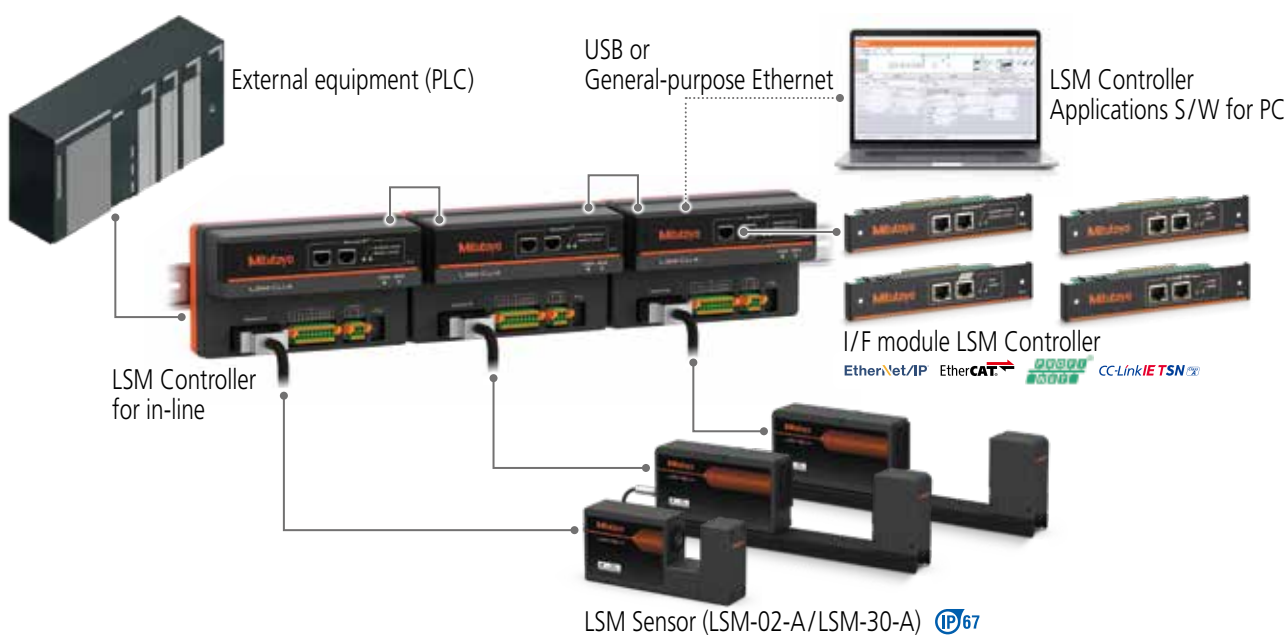

LINE UP

Sensor unit features



LSM-30-A



LSM-02-A

- Proven accuracy developed by one of the most trusted precision measurement instrument manufacturers
 - ✓ Guaranteed repeatability of 2σ
 - LSM-02-A ($\varnothing 1$ mm): $\pm 0.015 \mu\text{m}$
 - LSM-30-A ($\varnothing 10$ mm): $\pm 0.06 \mu\text{m}$
 - ✓ Guaranteed linearity:
 - LSM-02-A: $\pm 0.3 \mu\text{m}$
 - LSM-30-A: $\pm 1.0 \mu\text{m}$
- LSM-02-A has a compact body that can fit anywhere
- LSM-30-A is a separable sensor whose emission/reception unit can be used separately
- LSM-02-A is equipped with ultra-fine wire measurement mode, capable of measuring outer diameter of $5 \mu\text{m}$
- IP67 rated
- High-accuracy scanning with a high-accuracy motor
 - ✓ Scanning rate: 3,200 scans/s

Controller features

LSM-CU-A



- Compact, thin design that fits in a distribution board or inside equipment
 - Body including cable can be stored in a 100 mm deep distribution board
- Easily mountable on a DIN rail without using a tool
- USB Type-C, I/O ports, and industrial interfaces (optional)
- Configuration software included as standard for easy configuration
- The unit can be turned 90 degrees, enabling flexible layout



Module unit features

I/F module



- Four types of interface are available so that you can select the right one to meet your production line requirements
- The controller design enables insertion of a module without changing the layout

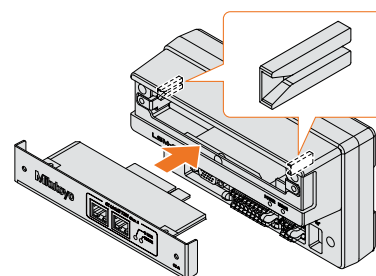

SOFTWARE [LSMPAK]

LSMPAK helps to ensure intuitive operation of LSM's measurement conditions (functions to use, Go/no-go judgment, etc.), execution of calibration, positioning of a workpiece to measure, etc. It can also be used to acquire and monitor measured values.

Point 1

Wizard instructions

Interactive wizard makes it quick and easy to go through the steps by simply selecting the desired items.

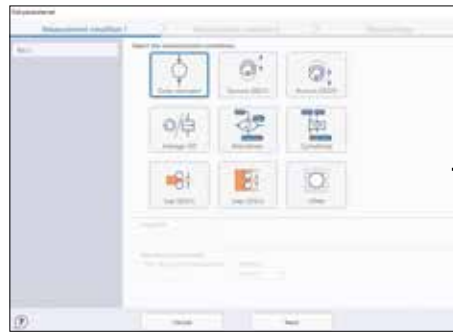

Measurement conditions selection screen



Advanced measurement conditions configuration screen

Point 2

Guidance function

Simple guidance is provided to explain unclear functions and names to quickly solve operator's problem. The function also includes a link to the PDF file of the user's manual to help ensure quick and correct configuration.

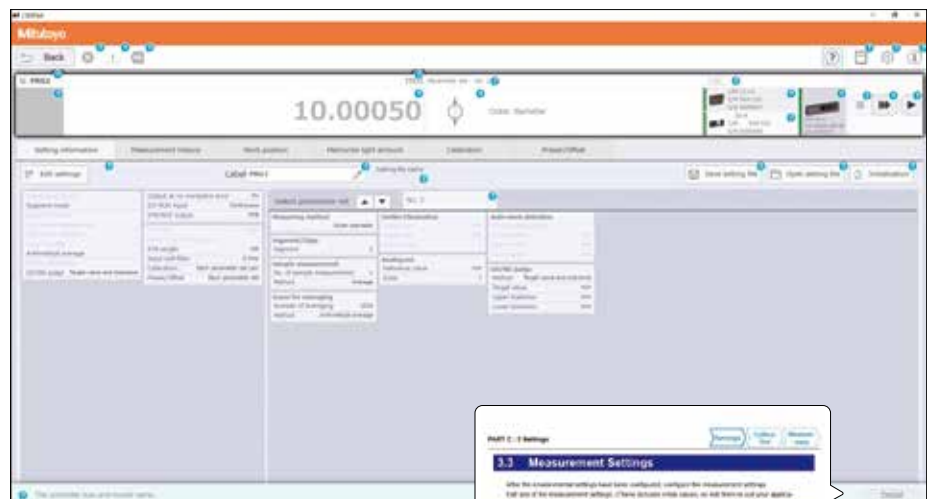

Clicking ? displays the simple guidance of each item

Displays the user's manual PDF

Point 3

Positioning of a workpiece

The optimum position of a workpiece with reference to LSM can be visually and quantitatively confirmed. This helps to ensure quick and correct positioning, enabling repeatable and stable measurement.

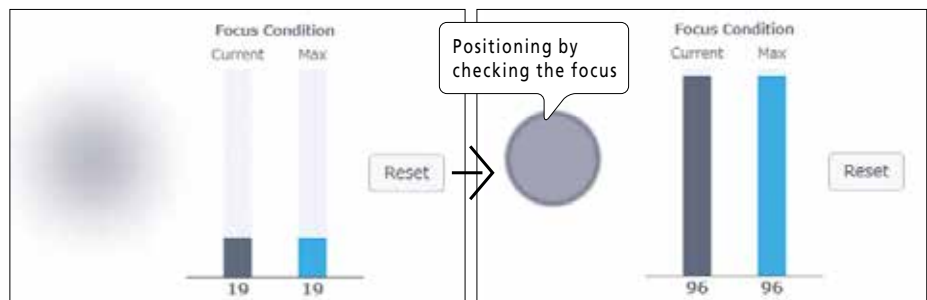

Before positional adjustment

After positional adjustment

■ Sensor unit

Specifications

Code No.		544-123	544-124
Model		LSM-02-A	LSM-30-A
Measuring range		0.005 to 2 mm 0.05 to 2 mm* ¹	0.3 to 30 mm
Resolution		0.01 μm	0.01 μm
Repeatability (2 σ)* ²	Full range	∅ 2 mm: ± 0.03 μm* ³	∅ 30 mm: ± 0.09 μm* ⁴
	Middle range	∅ 1 mm: ± 0.015 μm* ³	∅ 10 mm: ± 0.06 μm* ⁴
Linearity* ²		± 0.3 μm* ⁵	Whole range: ± 1.0 μm* ⁵ Narrow range: ± (0.6+0.1 ∠ D) μm* ^{5*6}
Positional error* ^{2*7}		± 0.4 μm	Full range (10 × 30): ± 1.8 μm Middle range (5 × 20): ± 1.0 μm
Measuring region		1 × 2 [optical axis depth] × [scanning width] mm	10 × 30 [optical axis depth] × [scanning width] mm
Number of scans for averaging		16 to 2048 scans * ⁸	1 to 2048 scans
Laser Class		Semiconductor laser: CLASS 1 (Max. output: 1.0 mW, Laser wavelength: 650 nm)	
Scanning rate		3200 scans/s	
Laser scanning speed		76 m/s	226 m/s
Protection level		IP67	
Distance between the emission unit and reception unit		—	Standard: 130 mm, Max.: 350 mm
Operating environment		Temperature: 0 °C to 40 °C, Humidity: 35%RH to 85%RH (non-condensing) Altitude: 2000 m or less	
Storage temperature		Temperature: -10 °C to 50 °C, Humidity: 35%RH to 85%RH (non-condensing)	
CE Marking/UKCA Marking		EMC Directive: EN IEC 61326-1, Immunity test requirements: Clause 6.2 Table 2 Emission limit: Class A RoHS Directive: EN IEC 63000	
Standard accessory		Signal cable: 02AGQ190 CD (User's Manual): 02AGQ039	

*1 When set to "Do not perform ultra-fine wire measurement" or "Edge specification" in the basic setup.

*2 Accuracy was inspected using a glass substrate workpiece with a vapor-deposited chromium pattern.

Environment: Temperature: 20 °C ± 1 °C, Humidity: 50% ± 10 °C

*3 Value of ± 2 σ when a ∅ 2 mm/∅ 1 mm gage is measured for two minutes at measuring intervals of 0.32 seconds (σ: standard deviation)

*4 Value of ± 2 σ when a ∅ 30 mm/∅ 10 mm gage is measured for two minutes at measuring intervals of 0.32 seconds (σ: standard deviation)

*5 Value obtained by measurement at the middle of the measuring range

*6 ∠ D = Difference in diameter between the master gage and workpiece. (Unit: mm)

*7 Error caused by moving a workpiece either in the optical axis direction or in the scanning direction

*8 When set to "Do not perform ultra-fine wire measurement" in the basic setup, one to eight times of averaging are available within the measuring range of 0.05 mm to 2 mm.

LSM-02-A

Unit: mm

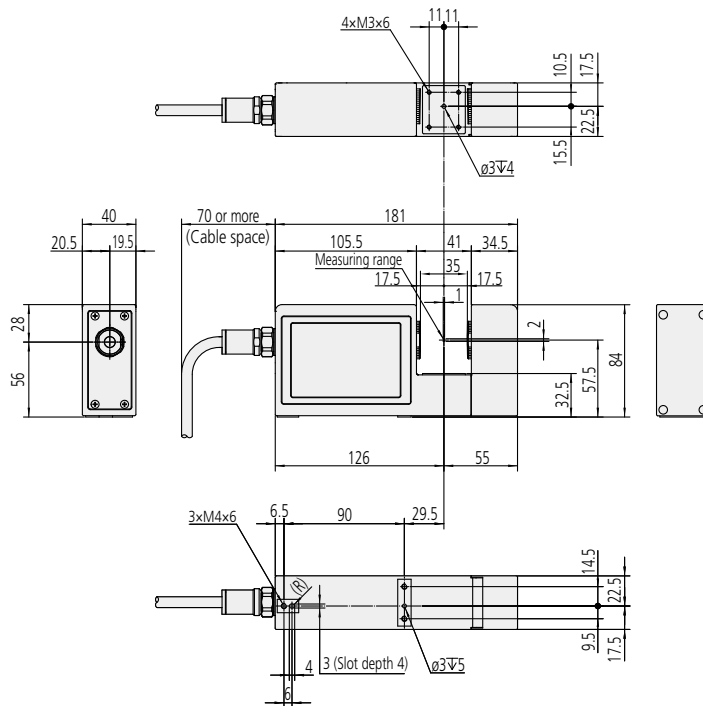

LSM-30-A

Unit: mm

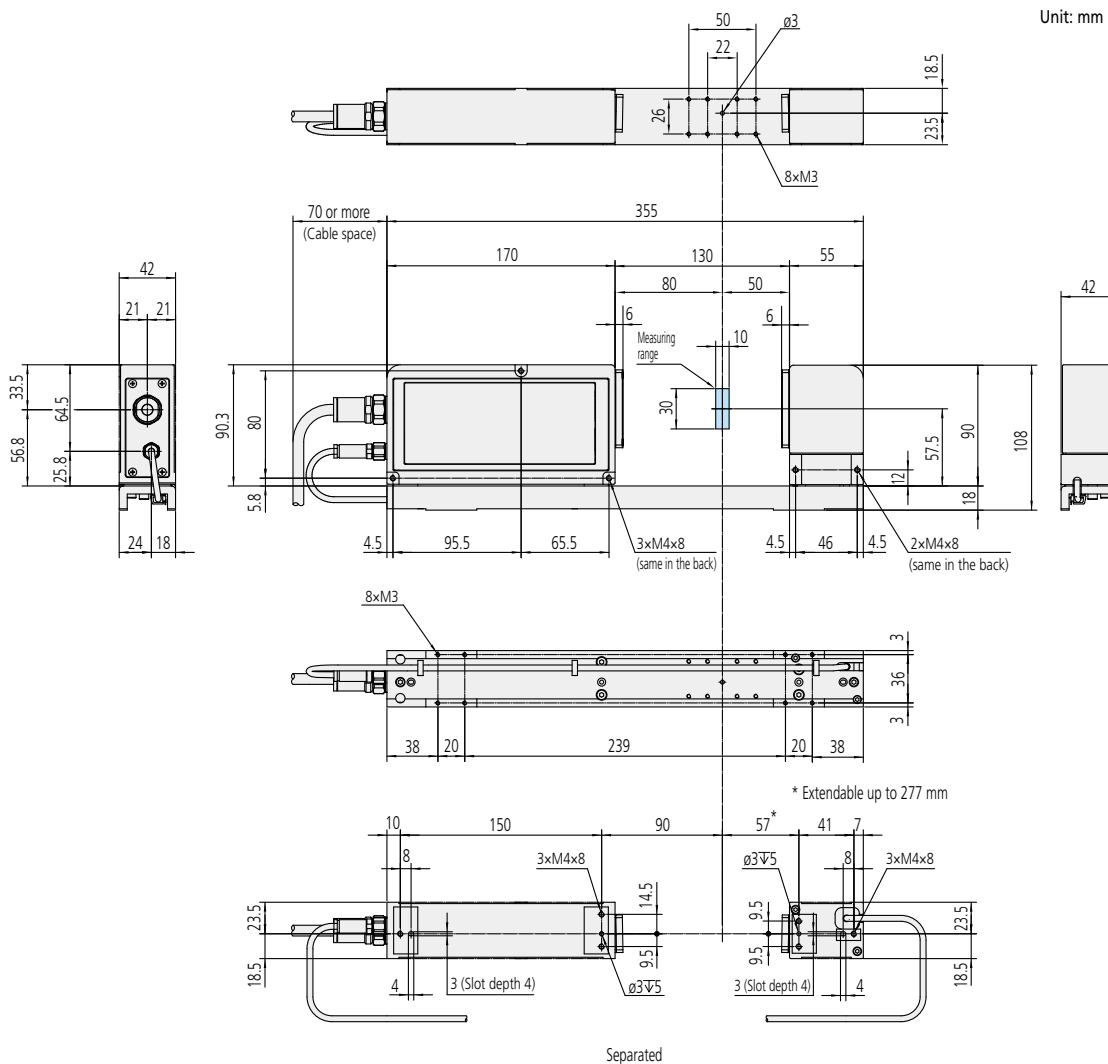

Separated

Controller

Specifications

Code No.		544-120 (metric) 544-121 (mm/inch switchable type)
Model		LSM-CU-A
Measuring functions *1	Segment mode	1 to 7 (1 to 3, transparent)
	Edge mode	1 to 255
	Averaging method	Arithmetic average: from 1 to 2048, Moving average: from 32 to 2048
	Functions	Transparent object measurement, Ultra-fine wire mode (LSM-02-A only), Simultaneous measurement of two items, Automatic workpiece detection, Outlier elimination, Judgment (lower limit/upper limit, multi-limit tolerance zone, target value and tolerance value), Dirt detection for protective glass, Sample measurement, Analog output, Parameter setting (Measurement condition): 20, Workpiece position, Calibration, Presetting, Offset, Statistical analysis, Calculation of two or more sets, Sensor model identification
Standard I/F	Indicator	[POWER] LED (green), [ERROR] LED (red)
	Signal cable connector	Mini D-Sub (15 pins)
	USB connector	Type-C
	I/O connector	Separate terminal block (18 pins)
	Power supply connector	Separate terminal block (6 pins)
Power supply		DC+24 V ± 10%, 3.0 A or more *2
Operating temperature		Temperature: 0 °C to 50 °C, Humidity: 20%RH to 80%RH (non-condensing) Altitude: 2000 m or less
Storage temperature		Temperature: -10 °C to 60 °C, Humidity: 20%RH to 80%RH (non-condensing)
Mass		Approx. 550 g
CE Marking/UKCA Marking		EMC Directive: EN IEC 61326-1, Immunity test requirements: Clause 6.2 Table 2 Emission limit: Class A RoHS Directive: EN IEC 63000
Standard accessory		Socket for I/O terminal block: D800-396 , Socket for power supply terminal block: D827-827 Grounding wire (4 m): 02AGQ068 CD (LSMPAK installer, User's Manual): 02NGA070

*1 Each function has its combination limit.

*2 Use an AC adapter/switching power supply with output of at least +24 V/3.0 A.

Reference AC adapter: Signcomplex/AC adapter 24V/3A DC Port diameter 5.5×2.1 mm, Power supply connector: KAUMO Co.,Ltd./Power supply connector O.D. 5.5 mm I.D. 2.1 mm
Switching power supply: OMRON Corporation/OMRON S8VS-12024

Interface Unit

Specifications

Code No.		02AGQ300	02AGQ370
Model		LSM-EI-A	LSM-EC-A
Communication standards		EtherNet/IP	EtherCAT
Interface	LED	NETWORK STATUS Indicator: Dual Color LED1 (red/green) MODULE STATUS Indicator: Dual Color LED1 (red/green)	RUN Indicator: Single Color LED1 (green) ERROR Indicator: Single Color LED1 (red)
	RJ45 connector	2 channels	
Ethernet communication	Communication port	RJ45 × 2	
	Communication speed	100 Mbps Full duplex	
	Cable used	Cat.5e or more STP cable	

Specifications

Code No.		02AGQ350
Model		LSM-PN-A
Communication standards		PROFINET
Interface	LED	RUN Indicator: Dual Color LED1 (red/green) ERROR Indicator: Dual Color LED1 (red/green)
	RJ45 connector	2 channels
Ethernet communication	Communication port	RJ45 × 2
	Communication speed	100 Mbps Full duplex
	Cable used	Cat.5e or more STP cable
PROFINET function	PROFINET RT	Conformance class B PROFINET device Media redundancy protocol (MRP) client Multicast provider and subscriber
	Min. cycle time	2 msec
	Maximum number of connections (ARs*1)	2
	Number of CRs*2 per connected controller	For cyclic data: 2, For parameter setting: 1

*1 AR: Application Relation, Type of AR: Device Access

*2 CR: Communication Relation

Interface Unit

Specifications

Code No.	02AGQ390	
Model	LSM-CC-A	
Communication standards	CC-Link IE TSN	
Interface	LED	D Link: Dual Color LED1 (red/green) ERROR: Single Color LED1 (red)
	RJ45 connector	2 channels
Ethernet communication	Communication port	RJ45 x 2
	Communication speed	100 Mbps Full duplex
	Cable used	Cat.5e or more STP cable
CC-Link IE TSN function	CC-Link IE TSN	Class A remote station
	Min. cycle time	1 msec

Common specifications

Operating environment	Temperature: 0 °C to 50 °C, Humidity: 20%RH to 85%RH (non-condensing)
Storage temperature	Temperature: -10 °C to 50 °C, Humidity: 35%RH to 85%RH (non-condensing)
CE Marking/UKCA Marking	EMC Directive: EN IEC 61326-1, Immunity test requirements: Clause 6.2 Table 2 Emission limit: Class A RoHS Directive: EN IEC 63000

Controller

LSM-CU-A

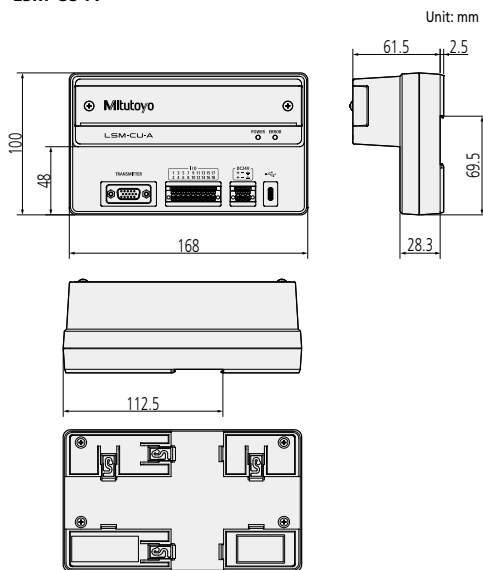

Interface Unit

LSM-EI-A

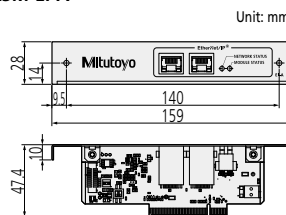

LSM-PN-A

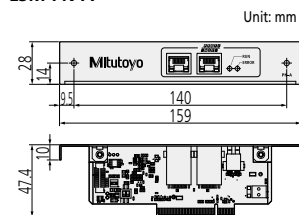

LSM-EC-A

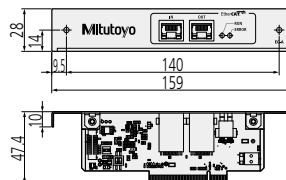

LSM-CC-A

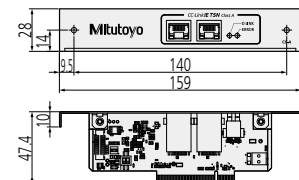

General Notes

Compatibility

LSM-02/30-A sensors and LSM-CU-A controller are not compatible with conventional models (LSM-3000/3100/4000/4100/400 Series, 5000/5100/5200/6000/6100/6200/500 Series, 500H Series, and 500S Series).

The workpiece and measuring conditions

Measurement error may occur depending on the shape or surface roughness of the workpiece. In this case, be sure to perform calibration using a reference gage or master gage that has a known shape or the same surface roughness as much as possible. If measurement values show a large degree of dispersion due to the measuring conditions, increase the number of scans for averaging to improve the measurement accuracy.

Electro magnetic interference

To avoid operational errors, do not route the signal cable and relay cable of the Laser Scan Micrometer alongside a high voltage line or other cables capable of inducing noise current in nearby conductors. Ground all appropriate units and cable shields.

Safety precautions regarding laser beam

This product uses a low-power visible laser for measurement and classified as a CLASS 1 laser product according to EN/IEC 60825-1. On LSM-02/30-A sensors, a CLASS 1 laser safety label as shown below is attached.

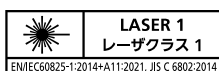

OPTIONS

Standard calibration gage set

These are standard gages for calibrating laser scan micrometers.
The dimension to be calibrated is one direction at one point which is marked on each gage.

For calibrating models		LSM-02-A	LSM-30-A
Set No.		02AGD110	02AGD130
Configuration (Code No.)	Stand	02AGD111	02AGD131
	Gages	ø0.1: 958200 ø2 : 958202	ø1 : 02AGD920 ø30: 02AGD961
	Carrying case	958203	02AGD980



LSM-02-A

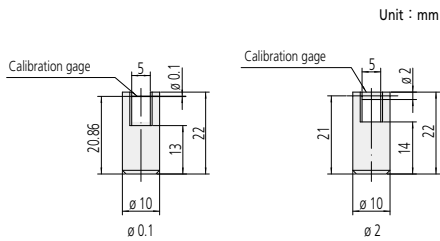

LSM-30-A

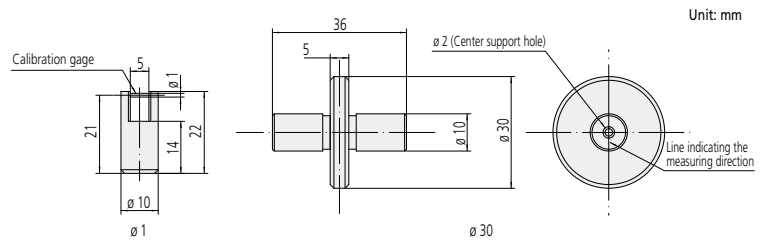

Wire guiding pulley

Used for supporting measurement of outside diameter of fine wire-like materials such as magnetic wire or fiber.

Model	LSM-02-A
Code No.	02AGD200

The measuring range is as below.
LSM-02-A: ø 0.1 mm to ø 1.5 mm
To measure a workpiece smaller than ø0.1 mm or larger than ø1.5 mm, contact one of our sales or customer service representatives.

Use a calibration gage set (02AGD110) for **LSM-02-A** for any workpiece if calibration is necessary.

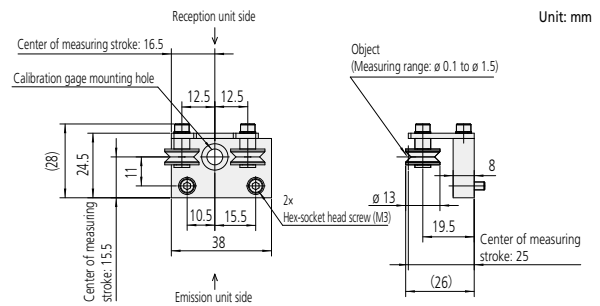

Air shield

If the emitter and receiver windows are clouded with smoke or dust, it can be prevented by blowing clean air from air outlets at the emitter and receiver.

Model	LSM-30-A
Code No.	02AGQ450

Note: A 5 m air tube (with ø6 mm outer diameter) is included with the air shield.

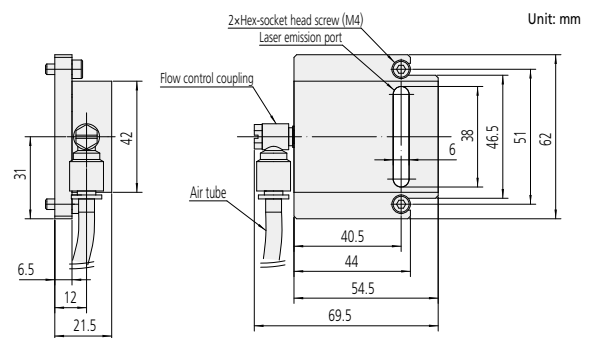

Laser beam stabilization shield

This suppresses variation of measured values caused by spatial fluctuation of the measurement environment.

Model	LSM-30-A
Code No.	02AGQ452

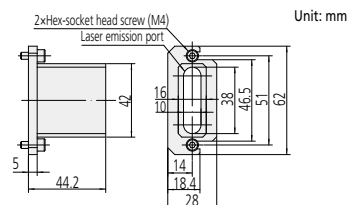

Workstage

This enables highly accurate measurement thanks to easy setup and height adjustment of shafts, etc.

Model	LSM-30-A
Code No.	02AGD270

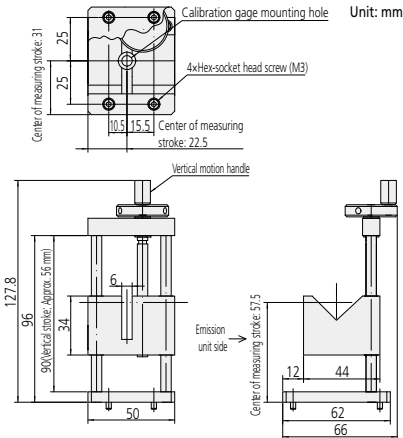

Extension signal cable/Extension relay cable

These cables are used when the measuring unit and display unit are placed far apart during use (extension signal cable) or when the emission unit and reception unit are placed apart during use (extension relay cable).

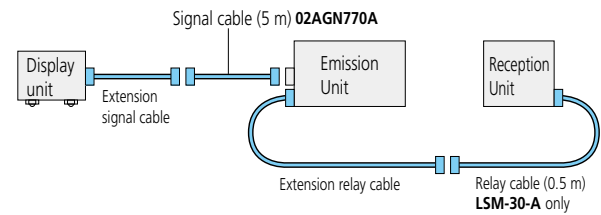

Extension signal cable

Code No.	Cable length
02AGN780A	5 m
02AGN780B	10 m
02AGN780C	15 m
02AGN780D	20 m

Extension relay cable

Code No.	Cable length
02AGQ464A	1 m
02AGQ464B	3 m
02AGQ464C	5 m

Note1: For **LSM-02-A**, the signal cable should be 20 m max. and the relay cable 2 m max.

Note2: For **LSM-30-A**, the signal cable should be 29 m max. and the relay cable 5 m max.

Note3: The total length of a signal cable and relay cable should be 29 m max.

Adjustable workstage (for LSM-30-A)

The mechanism allowing vertical and horizontal sliding helps to ensure easy outside diameter measurement of various workpieces. It is useful for quality control of precision shafts, rollers, and pin gages.

Code No.	02AGD490
Measuring range	0.3 to 30 mm
Horizontal stroke	200 mm
Vertical stroke	35 mm
Maximum loading mass	2.0 kg
Mass	4.9 kg
Standard Accessories	V-block (02AGD420) × 2 Stop (02AGD430) × 1
Optional accessories	Center support (02AGD440) Adjustable V-block (up/down) (02AGD450)

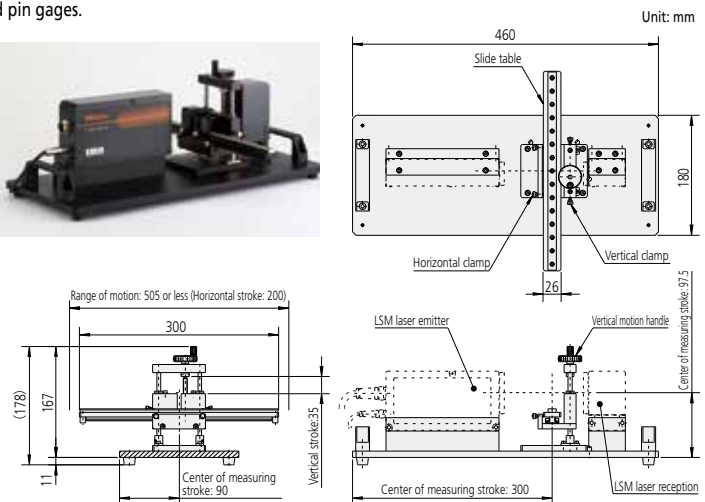
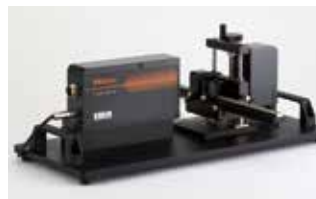

Adjustable workstage Standard Accessories (for LSM-30-A)

V-block

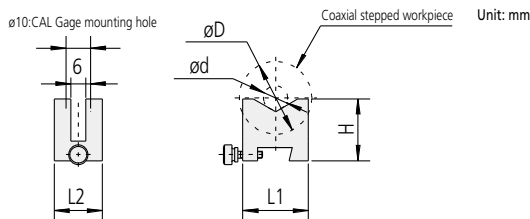

Code No.	02AGD420
Workpiece diameter ϕD_{max}	30 mm
Spigot diameter ϕd_{max}	30 mm
$(\phi D - \phi d)$ max	25 mm
Mass	0.03 kg (Weight per unit)
Remarks	Supported CAL gages $\phi 1$ (02AGD920) $\phi 10$ (229317) $\phi 25$ (02AGD963) $\phi 30$ (02AGD961)

Stop

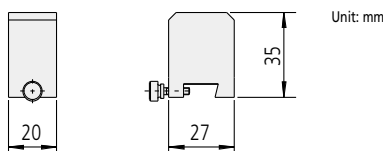

Code No.	02AGD430
Mass	0.05 kg
Application	Positioning of workpiece

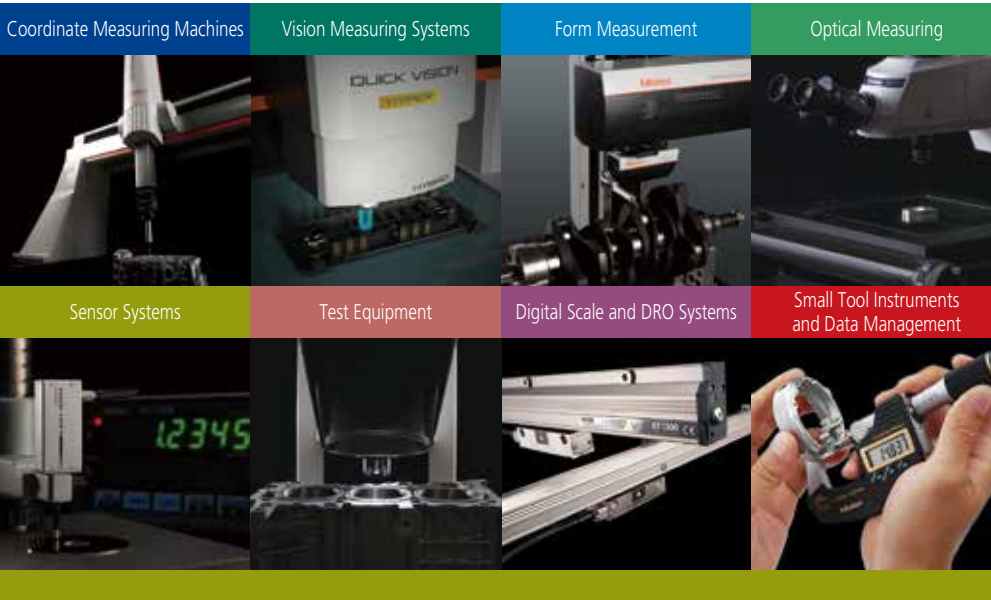

Whatever your challenges are, Mitutoyo supports you from start to finish.

Mitutoyo is not only a manufacturer of top quality measuring products but one that also offers qualified support for the lifetime of the equipment, backed up by comprehensive services that ensure your staff can make the very best use of the investment.

Apart from the basics of calibration and repair, Mitutoyo offers product and metrology training, as well as IT support for the sophisticated software used in modern measuring technology. We can also design, build, test and deliver measuring solutions and even, if deemed cost-effective, take your critical measurement challenges in-house on a sub-contract basis.



Find additional product literature and our product catalogue

<https://www.mitutoyo.co.jp/global.html>

Our products are classified as regulated items under Japanese Foreign Exchange and Foreign Trade Law. Please consult us in advance if you wish to export our products to any other country. If the purchased product is exported, even though it is not a regulated item (Catch-All controls item), the customer service available for that product may be affected. If you have any questions, please consult your local Mitutoyo sales office.

Note: Product illustrations are without obligation. Product descriptions, in particular any and all technical specifications, are only binding when explicitly agreed upon.
MITUTOYO and MICAT are either registered trademarks or trademarks of Mitutoyo Corp. in Japan and/or other countries/regions. Other product, company and brand names mentioned herein are for identification purposes only and may be the trademarks of their respective holders.
All information contained in this brochure is current as of July 2023.

Mitutoyo

Mitutoyo Corporation

20-1, Sakado 1-Chome,
Takatsu-ku, Kawasaki-shi,
Kanagawa 213-8533, Japan
T +81 (0) 44 813-8230
F +81 (0) 44 813-8231
<https://www.mitutoyo.co.jp>